

Model **ELVIS**



Guarantee

Frame Lifetime guarantee

Seat Suspension 10 years

Rest of Pieces 2 years*

*6-month guaranty extension by activating it on the web

Technical Information

Frame _____ Frame of pine wood and MDF

Seat Suspension _____

Back Suspension _____

Seat Foam _____ 35Kg Foam on seat cushions + Fibre

Seat Firmness _____ Medium Foam (white) *

Back Cushions _____ Not included

Loose Cushions _____ Not included

Legs Options _____ Swivel leg

Colors _____ With o without castors

Comments: _____ * You would like to know more?
Check the FAQs section in our website

Cushions Measures

Measures

Scheme

Width	59 cm
Height	75/85 cm
Depth	58 cm
Seat Height	48 cm
Arm Height	69/79 cm
Back Height	45 cm
Depth when open	- cm
Net Weight	19 kg
Gross Weight	20 kg
Volume m3	0,21 m3

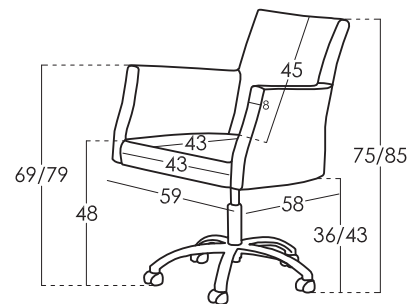

Packaging

Shrink wrapping plastic packaging with protective corner brackets

Options



Types of Standard Foam

Hardness: Soft: Grey colour 35Kg	Hardness: Medium: White colour 35Kg	Hardness: Hard: Green colour 30Kg
--	---	---

Types of Fire Retardant Foam

Hardness: Medium: Grey colour 41Kg	Hardness: Soft: White colour 36Kg
--	---

* You can request a different seat hardness from the standard of the model with a small price increase

ELVIS is manufactured by Fama Sofas, whose quality system is certified by AENOR and IQNET, according to ISO 9001-2008, with certificate number ER 0790/1999.

All models have passed the tests required for granting the quality control label from Aidima-Cetem laboratories.



Enjoy the new design
made in
Spain

fama